

FFT GYRO 600 PRO CARBON

The new FFT GYRO 600 PRO is designed for you to test bigger and heavier drones, with less aerodynamic interference and with the power of robotics, so you can automate your tests and put to the limit your multi-rotor UAV.

DEVELOP AND IMPLEMENT WITH UAVs FASTER



The FFT GYRO* is a test-bed system that would allow you to **implement** your development **easier, faster** and **without the risk** of a collision. Save time and money and **focus on changing the game with your innovation**.

The system helps to understand, **develop**, and implement new **mechanics, electronics and software** for vertical take-off and landing vehicles without putting at risk the equipment. It can be connected to a PC to **accelerate the test, implementation, and validation** of the development. Focus on your work, do not waste time with technicalities, **lead in drone innovation**.

HOW IT WORKS

The system is a platform that has a structure like a 3 DOF Gyroscope (see Fig 2). A multi-rotor can be attached to a base, which can hold different types and sizes and align the geometric center to the center of rotation of the FFT GYRO, letting the vehicle move about its real geometric center, and not eccentrically like in other platforms. This base is mounted inside an inner gimbal which in turn is mounted inside an outer gimbal. The structure is designed to allow free rotation about the main axes of a rigid body (see Fig 1), so the airship can rotate freely. The gimbals are equipped with slip rings, so there is no limitation in the rotation of the parts and the electronic connections. The system has three high-resolution magnetic absolute multi-turn encoders to measure the true roll, pitch, and yaw angles of the drone. And the DC motors can simulate external forces as disturbances, to perform validations of the robustness for the control laws, or to automate the calibration or validation phase. The gimbals are made of high-quality light and strong materials, to reduce the inertia that might be added to the system and maintain the properties of a rigid structure. The external structure is made of aluminum, to reduce the weight and ensure the long durability of the overall system.

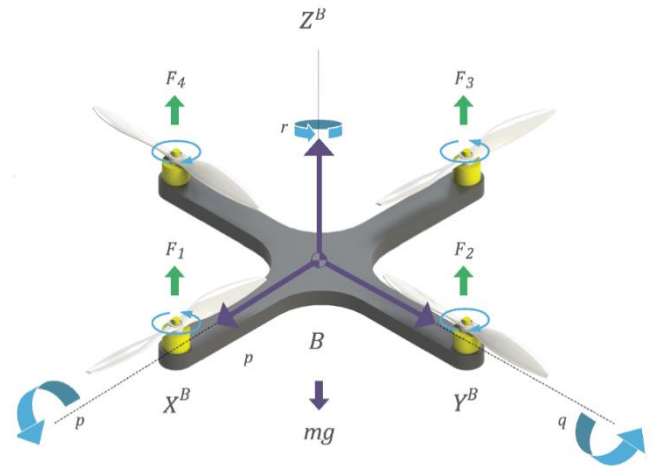

Fig 1. Principal dynamics of a multi-rotor

The FFT GYRO allows researchers and drone developers to perform experiments and tests with more reliable and efficient results, which significantly reduce the uncertainty of aircraft sensors on board and even allowing to improve and automate calibration techniques for these sensors.

FFT GYRO WORKSTATION COMPONENTS

- FFT Gyro frame
- FFT Gyro electronics
- FFT Gyro interface software for MATLAB / Simulink
- User Manual and Quick Start Installation Guide (digital)

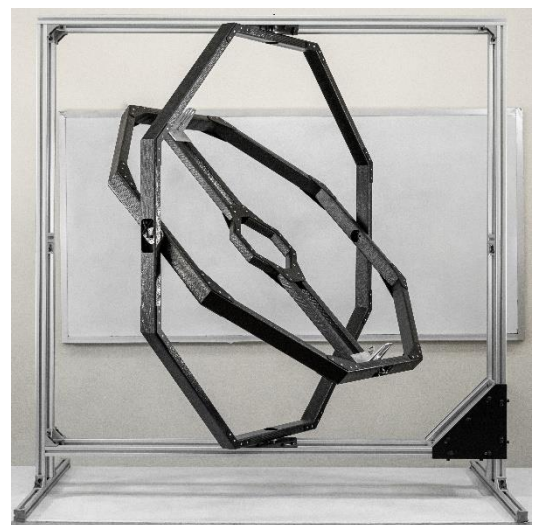
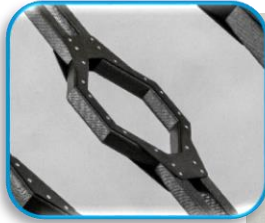

Fig 2. System specifications on reverse page.

SYSTEM SPECIFICATIONS

FFT GYRO

Light and strong materials, reducing the extra weight to de vehicle.



High-resolution magnetic encoders, to measure roll, pitch and yaw angles.

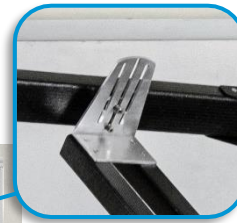
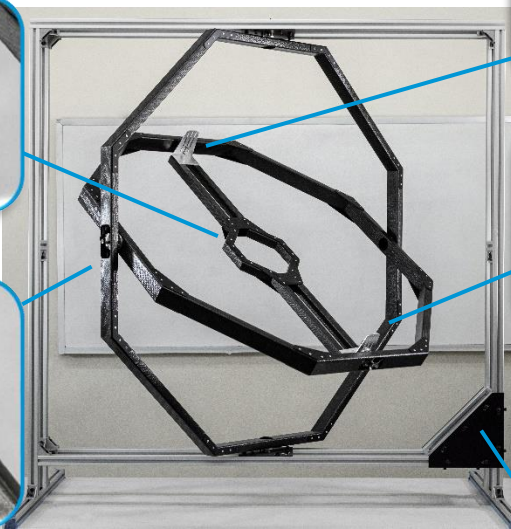
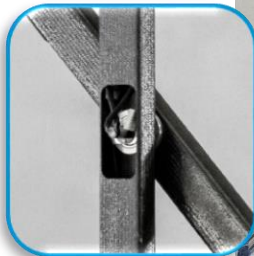

Adjustable height for different types of multi-rotors



Slip-rings provide absolute free rotation in the 3 DOF



Led status indicators and USB port to connect to PC.

FEATURES

- Compatible with different types of multi-rotors, and sizes, from 450mm to 600mm length from rotor to rotor, or up to 950 mm outer diameter (with propellers).
- Three degrees of freedom about the main axes, roll pitch and yaw angles.
- Slip rings of that allows free rotation about any of the Euler angles.
- High-resolution magnetic absolute encoders, with multiple turns. (12 bits)
- Mechanically balanced design, reducing any disturbance in the rotation dynamics.
- High-quality carbon fiber and aluminum material gimbals, strong for reducing deflection issues and light to minimize extra weight and inertia added to the vehicle dynamics.
- Sensing and control operation from MATLAB / Simulink.
- Robust and heavy-duty machined components.
- External aluminum frame, that can be customizable.
- Motors can be added to simulate external forces (sold separately).

DEVICE SPECIFICATIONS

Dimensions – L x W x H	133 cm x 133 cm x 144 cm (unfold).
Device mass	21 Kg.
Encoder resolution	0.0879° (12-bits).
Motor power	15.3 Kg · cm.
Plate (roll) mass and inertia	850 g – 3.58E+06 g·mm ² (about roll axis).
Inner Gimbal (pitch) mass and inertia	1450 g – 2.05E+08 g·mm ² (about pitch axis).
Outer Gimbal (yaw) mass and inertia	1550 g – 2.60E+08 g·mm ² (about yaw axis).
Roll, pitch, and yaw range	360° (multi-turn).
Multi-rotor compatible sizes	From 450mm to 600mm rotor to rotor distance, or up to 950mm outer diameter.
Power specs	12 V, 5 A, 120W.
Communication protocols	USB2.0, serial port, acquisition speed up to 100 Hz.

SYSTEM DIMENSIONS

All dimensions are in millimeters.

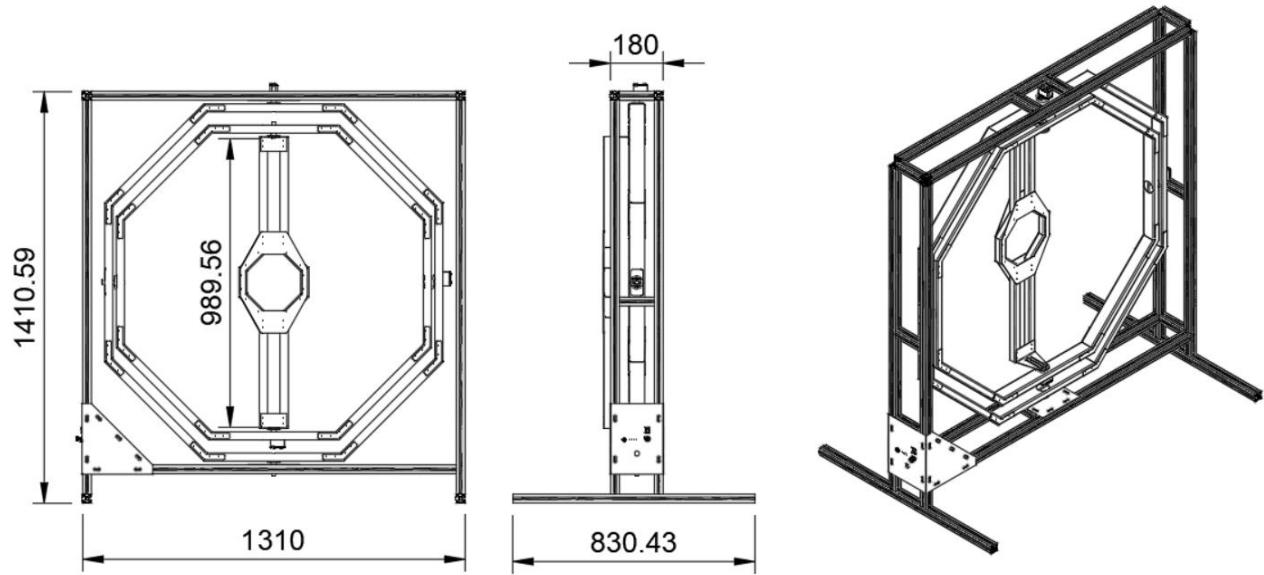

Figure 1. Principal dimensions of the FFT GYRO 600 PRO CARBON